



What is the RP 410?

The RP 410 is an 8.4" transfective colour touchscreen with full VGA definition. Suitable for consul mounting, the RP 410 is the clearest, safest way of communicating the condition and operating parameters of the equipment to the crew. With simple, easy to use "touchscreen" functionality, the information and controls are displayed graphically and with icons for navigation. Highly effective for use in direct sunlight, but also equipped with auto dimming and a night mode, the RP 410 can be installed anywhere on the vessel. The unit connects to the DCU modules via a simple Ethernet connection, or via Ethernet switches if multiple panels required. The RP 410 is approved by 10 Classification Societies, including supporting all requirements for Master panel, Active station and remote alarm suppression. It also supports multiple engines and accessories.

Why more customers select the RP 410

The RP 410 requires no on site configuration. Once connected to the DCU, it automatically configures itself. With 10 languages installed as standard, with easy "on the fly" changes, operation becomes safer and clearer. The Owner can select from 20 different templates to provide the preferred panel layout, and uploading and downloading of files (including wallpapers) and information can take place using the USB connection. By using the password protected areas, certain parameters of the panel can be adjusted locally if required. Additionally by reading the J1939 databus available on most electronic engines today, the RP 410 will deliver fault codes, not only as a numeral, but as a plain text description of the event / alarm, providing clear indication to allow operators to take the appropriate actions. Multiple engines can be displayed on a single panel (1-8 limit). The RP 410 can also support up to 4 IP cameras, either to monitor engine spaces or provide security coverage, all without a dedicated CCTV system.

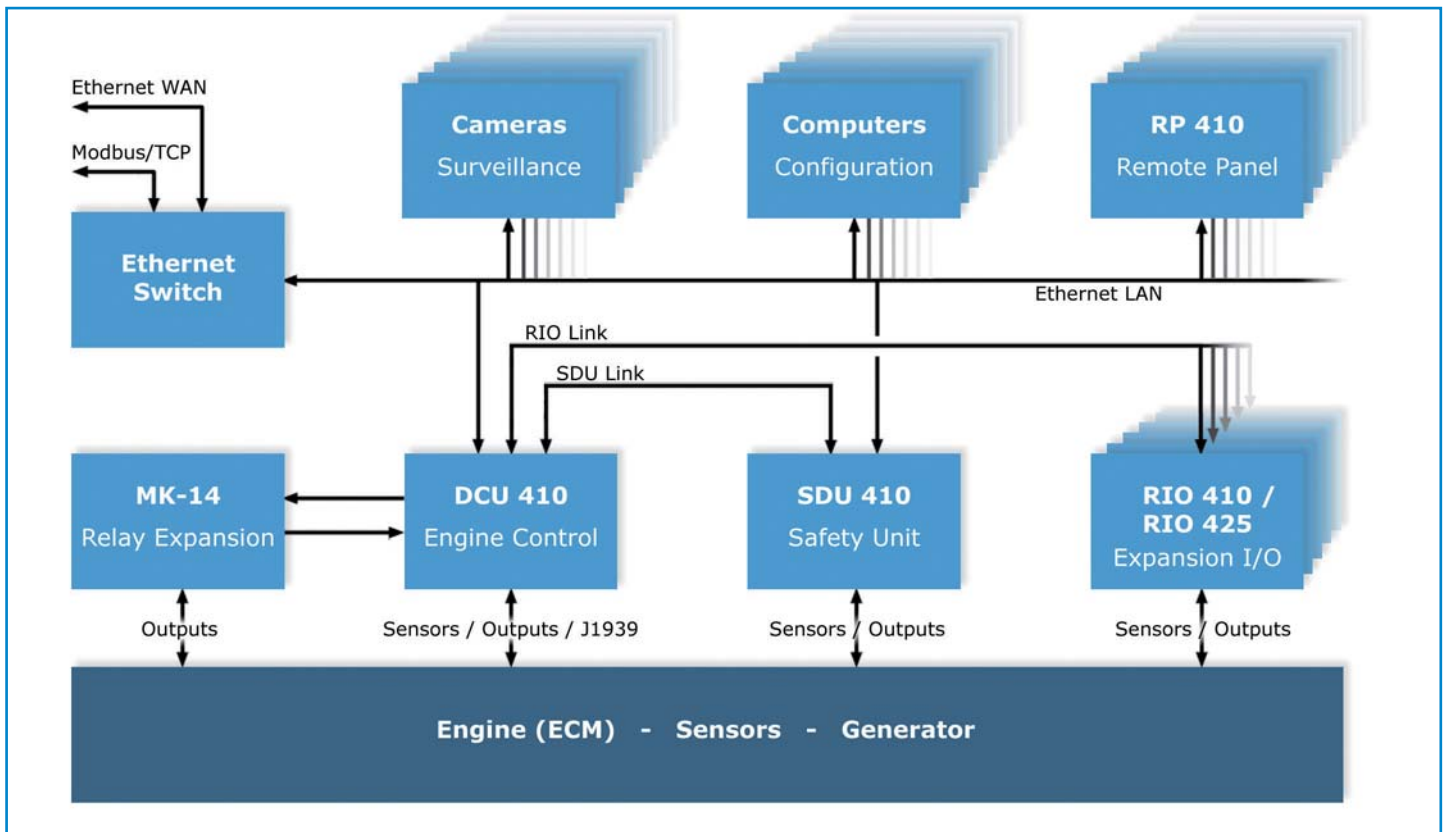

Features and Benefits

Clear, precise indications

8.4" Transflective touchscreen panel, 800 x 600 pixel

- Selectable Auto dimming mode dependant on ambient light plus a night mode

- Multiple Sounds available and linked to specific events provide unique identification of event

- Intuitive operation via icons rather than text

Ease of installation

Communicates via Ethernet – only one cable required

- Multiple engines can be displayed on one panel

- No special tools to connect

No user configuration required

Automatically configures itself when connected to a DCU

- Automatic "conflict" notification if new configurations loaded elsewhere

- Backup possible via a standard USB connection

Multiple monitoring positions

No practical limit to number of monitoring positions

- 1200 m installation limit from DCU

- Each RP 410 dedicated to specific DCU's if required

- Multiple languages (10) including Chinese and Russian installed

Sales and Marketing

Auto-Maskin UK Ltd

SATRA Innovation

Rockingham Road, Kettering,

Northants NN16 9JH, United Kingdom

Tel.: +44 (0) 1536 533290 Fax: +44 (0) 1536 569369

E-mail: office@auto-maskin.no

Web: www.auto-maskin.co.uk

Ordering Info

Item

DCU 410:

DCU 408:

SDU 410:

RIO 410:

RIO 425:

RP 410:

MK-14:

Part Number

1006450

1006455

1006451

1006453

1006457

1006452

1121252



RTNA

